

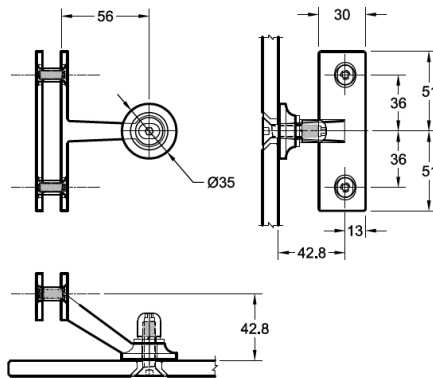

Product Image

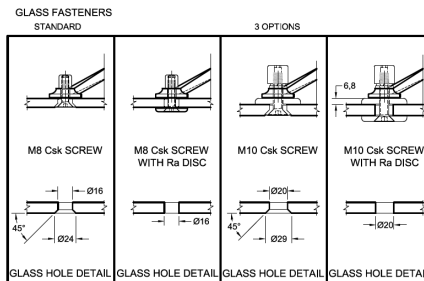

Dimensions



Glass Preparation

DETAILS

Light Weight Spider

- Standard with M8 csk fixing or the 3 other options shown
- Larger glass preparation diagrams on page 3.8k
- Specify glass thickness and fixing type
- **If you are unsure what to order please email manufactured@mfgs.com.au**

FINISHES

- Polished
- Satin

Base material: 316 Stainless Steel