



VAHO GLASS



SV-X50

Technical Details

MINIMUM SPACE, MAXIMUM COMFORT

SV-X50 is a frameless sliding glass shower door system that combines the latest technological developments with an attractive minimalist design.

- 1. Compact** aluminum sliding **track** that conceals all the mechanisms; thus, achieving an unbeatable aesthetic appearance.
- Available in **different finishes**: brushed nickel aluminum, polished chrome aluminum, satin brass aluminum and matt black anodized aluminum.
- 3. Installation** wall-wall, wall-glass, glass-glass and angular (90°)
- Suitable for **glass thicknesses** of 8 and 10mm (only 8mm for angular)
- 5. Quick and easy installation** thanks to the frontal access to all components and its adjustments and regulations.
- 6. Ball bearing rollers** for a smooth and silent sliding action.
- 7. Double SofTop damping system**: thanks to the latest developed damping technology, the opening effort is minimal as it has been reduced by almost 40%. Likewise, a smooth and silent closing in the last 7cm of the sliding path is achieved. The double SofTop damping system protects the system from impact damage, thus extending the useful life of the product and with only a minimum door width of 630mm required.
- 8. Applus+ Certificate**: Durability grade 6: 100.000 test cycles and Corrosion grade 4 = 240h according to EN1527 standards.
- 9. Optional accessories**: horizontal water seals and sealing gaskets that can be easily removed for cleaning and/or changing.

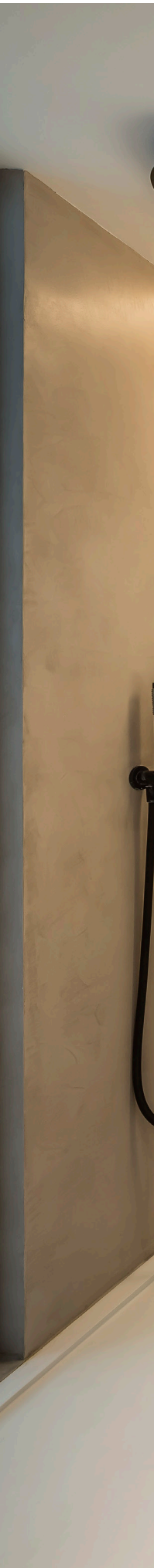



Mounting wall-to-wall

SV-X50

Technical characteristics

Technology and ease of installation

Profiles

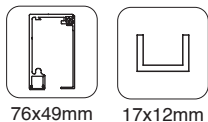

Specifications

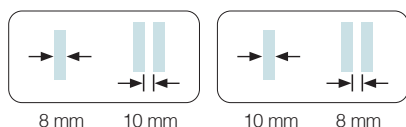

8 mm 10 mm 10 mm 8 mm

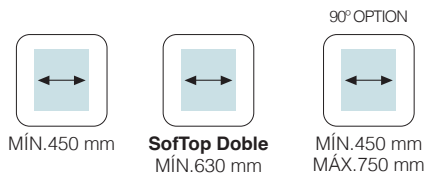

MIN.450 mm **SofTop Doble** MIN.630 mm MIN.450 mm MÁX.750 mm



90° OPTION SofTop Doble MIN.630 mm MÁX.750 mm

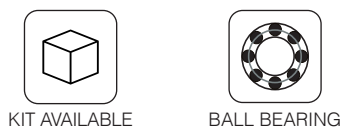

KIT AVAILABLE BALL BEARING

Weight

50 kg	110 lb
-------	--------

90° OPTION

30 kg	66 lb
-------	-------

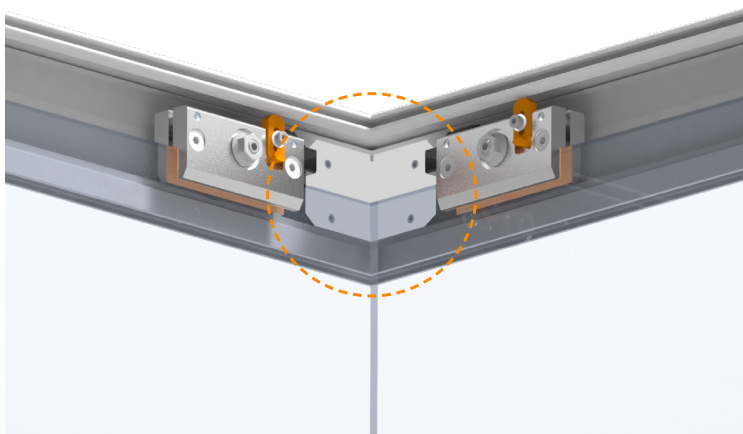
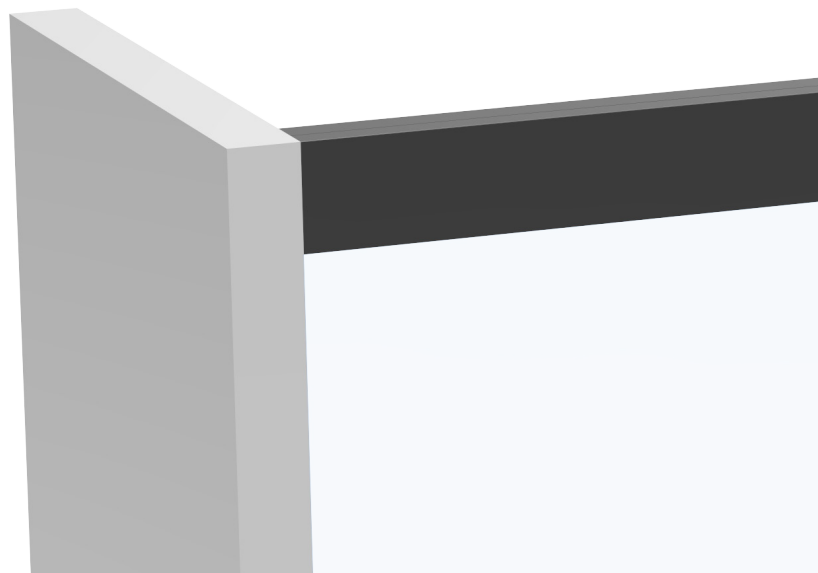

Angular connector for easy installation as it does not require any drilling. Designed to avoid any possible bending of the angle thanks to its high load capacity. The profiles are supplied cut at 45°.

Certificated product



Durability grade 6:
100.000 test cycles
and Corrosion grade 4
= 240h.

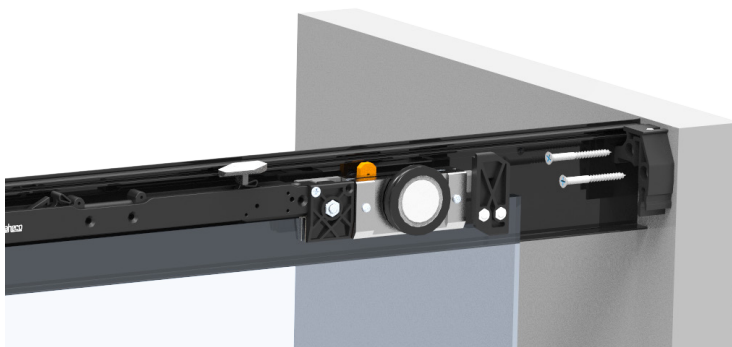

Hidden floating wall and glass mounting brackets.



DOUBLE SOFTTOP: thanks to the **latest developed damping technology**, the **opening effort** is minimal as **it has been reduced by almost 40%**. Likewise, a smooth and silent closing in the last 7cm of the sliding path is achieved. The double SofTop damping system protects the system from impact damage, thus extending the useful life of the product and with only a minimum door width of 630mm required.

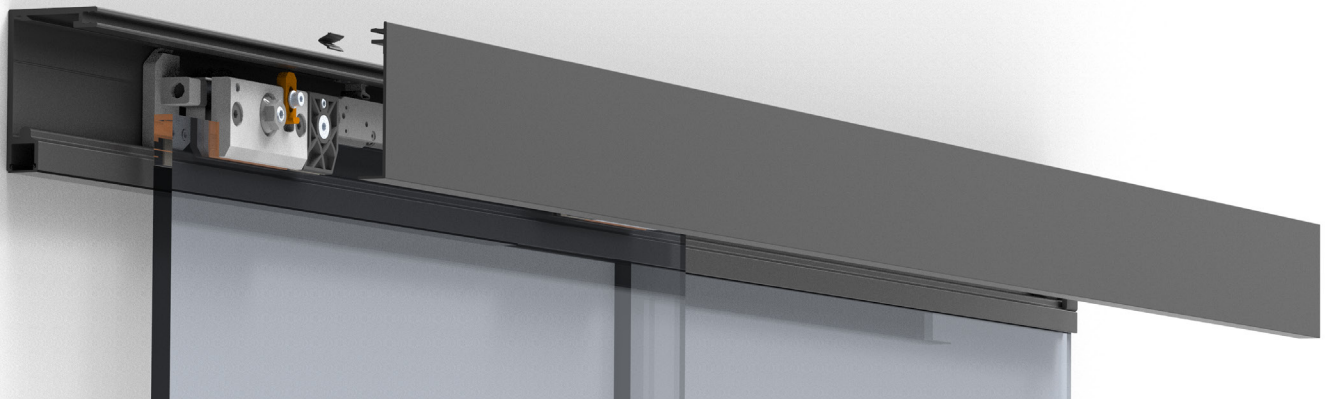

Frontal access to all components and its adjustments and regulations. The lateral top cover track is clipped to save installation time.

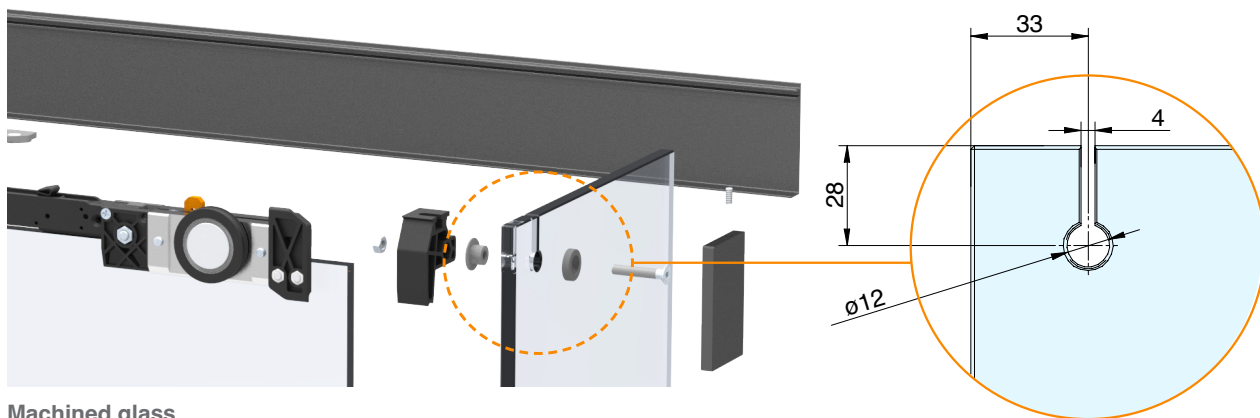

Machined glass

Compact and sleek design

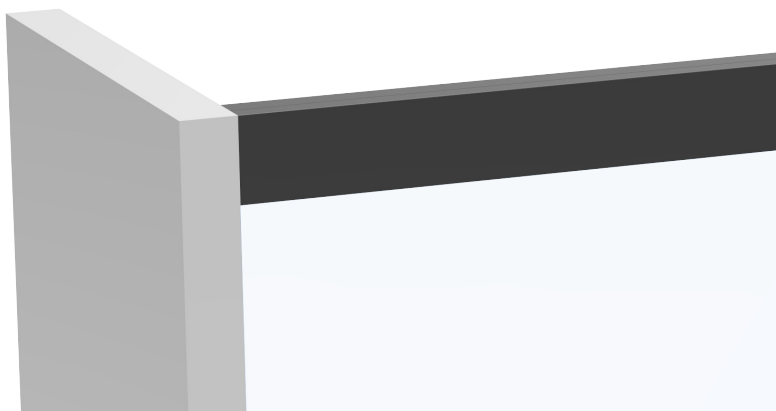

Smooth and compact track (76x49mm) in different finishes available that offers excellent possibilities for integration into any type of architectural design.

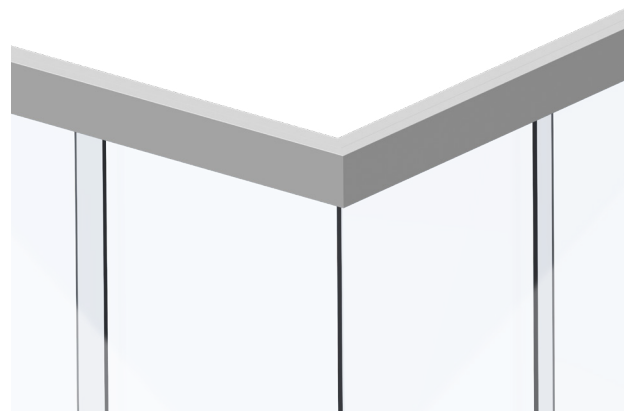

Internal angular connector for joining the two tracks at 90°, leaving the visible surface of the track with a clean and linear finish.

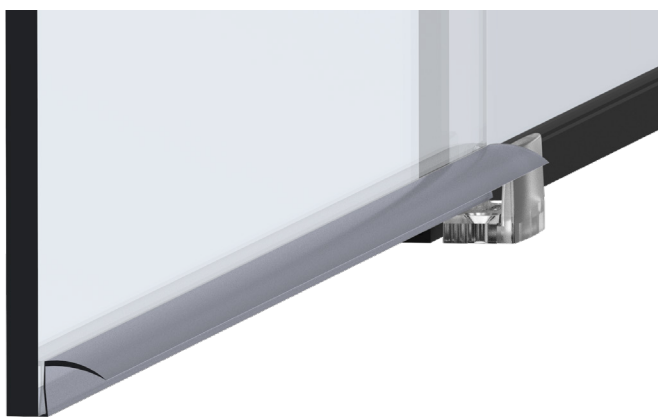

Transparent plastic bottom guide (resistant to UV rays) for optimal visual aesthetics. **Water seals, edge water seals and sealing gaskets available**, easy-to-remove for cleaning and/or changing.

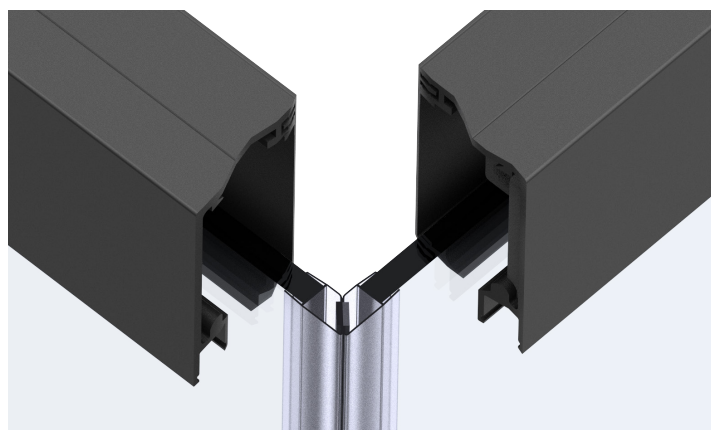

Available finishes



Brushed nickel aluminium
Shiny



Polished chrome aluminium
Shiny



Satin brass aluminium
Shiny



Matt black anodized aluminium



Mounting glass-to-wall



Project by Servicons Reformas & Interiorismo

Mounting wall-to-wall



Mounting glass-to-wall

Installation possibilities

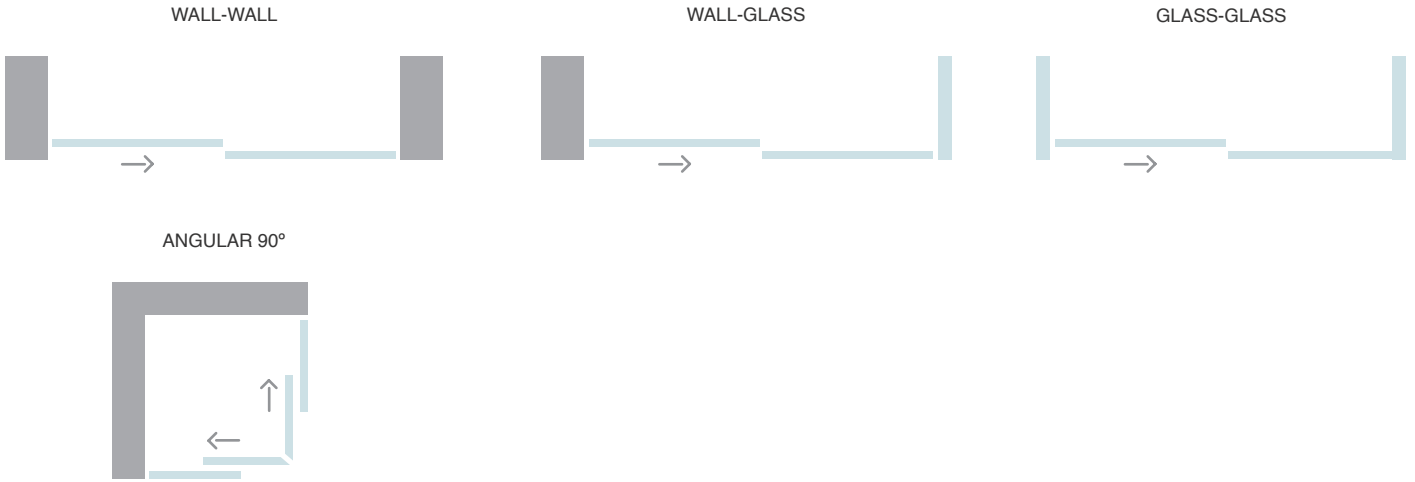

Cross-section

(Dimensions in mm)

KIT 1 SV-X50

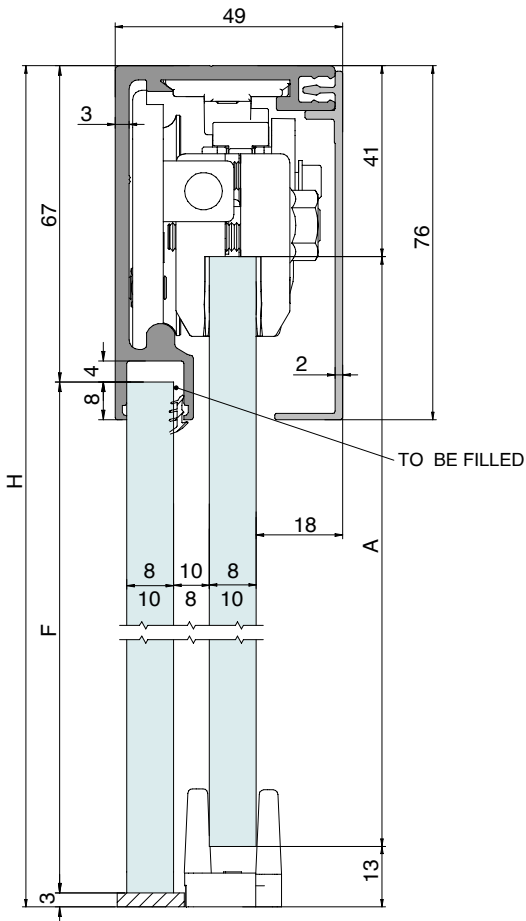

$F = H - 70$

$A = H - 54$

KIT 2 SV-X50 90° ANGLE

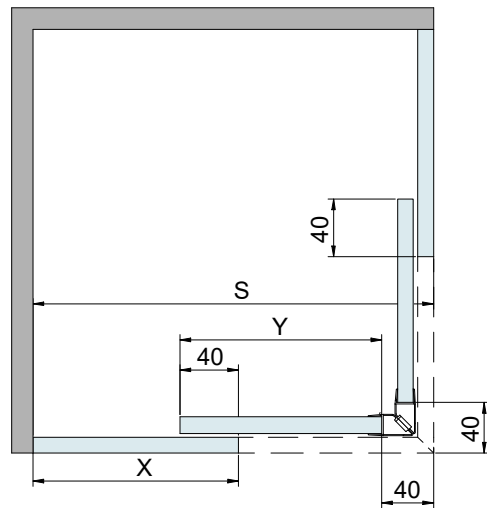

S=TRACK LENGHT

X= S/2

X=Y

90° CORNER		Shower tray	Door width	Max. weight
Without Softop	Min.	900x900	450	30 kg
	Max.	1500x1500	750	
With Softop	Min.	1260x1260	630	
	Max.	1500x1500	750	



Cross-section

(Dimensions in mm)

KIT 2 SV-X50 90° ANGLE I SECTION MINIMUM PANEL WIDTH, SOFTOP OPTION

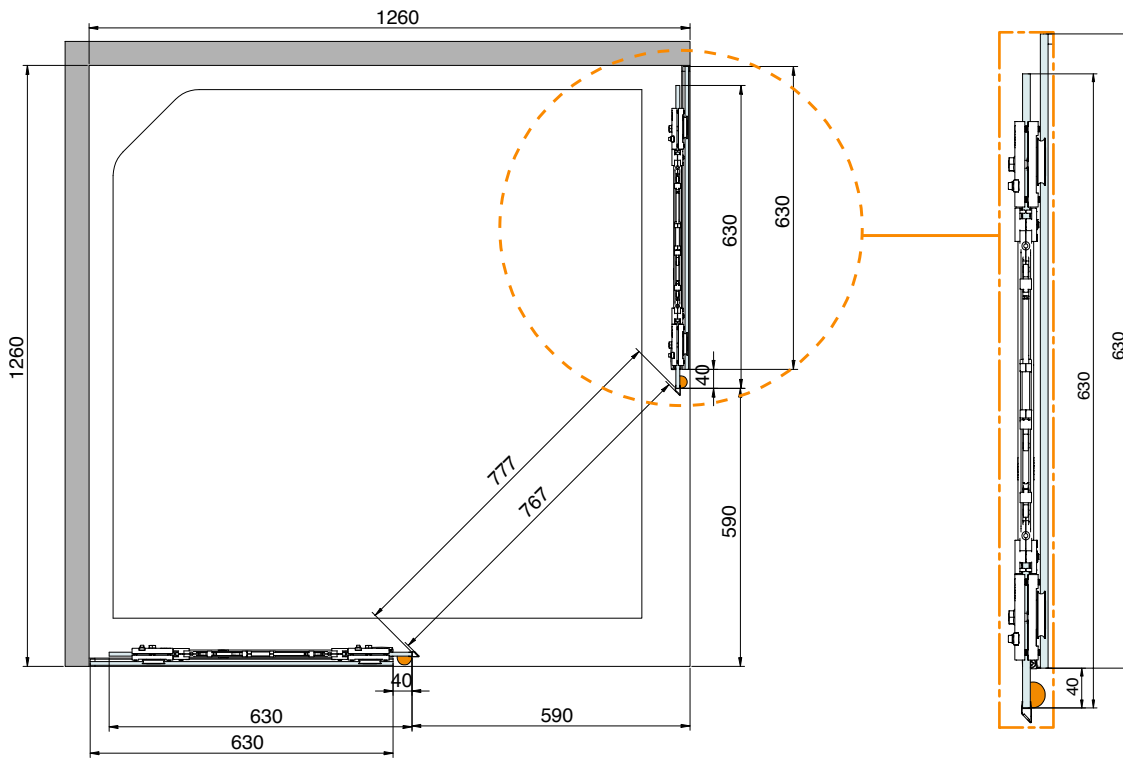

KIT 2 SV-X50 90° ANGLE I SECTION MINIMUM PANEL WIDTH, OPTION WITHOUT SOFTOP

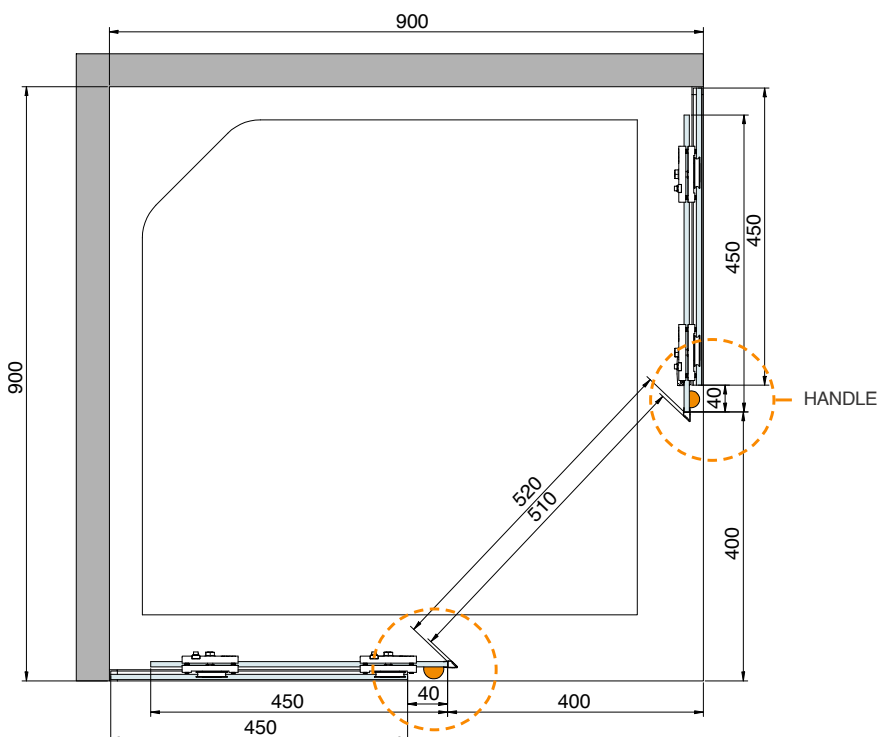

Components

KITS

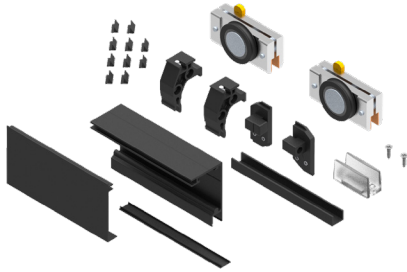

SV-X50 - KIT 1
x2 Retaining stopper

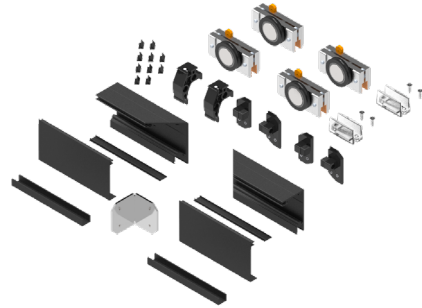

SV-X50 kit angular 90° - KIT 2
x2 Retaining stopper

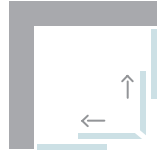

ACCESSORIES



SV-X50 Double SofTop

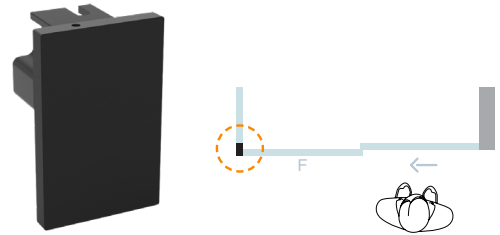

SV-X50
Fixed glass mounting bracket 90°. Left

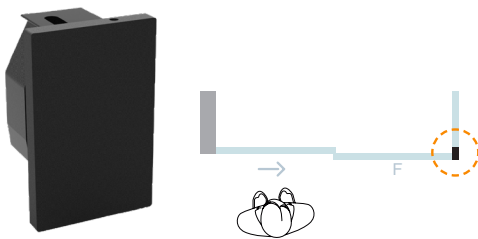

SV-X50
Fixed glass mounting bracket 90°. Right

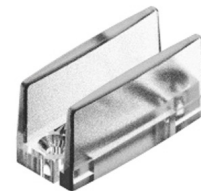

SV-X50
Plastic bottom guide for glass of 8-12mm

Vaho Glass

SV-X50



Polígono Industrial de Foradada / 08580
St. Quirze de Besora / Barcelona / Spain
T +34 93 852 96 15
export@saheco.com
saheco.com

MFGS

MODERN FRAMELESS
GLASS SYSTEMS

Modern Frameless Glass Systems Pty Ltd

Unit 2/55-57 Alexander Avenue Taren Point NSW 2229

E customer.service@mfgs.com.au P 02 95223983

www.mfgs.com.au